

Alpha air

INNOVATION



Alpha

INOX



ATTUATORI INOX 90° - 120° - 180°



ACTUATORS INOX 90° - 120° - 180°



STELLANTRIEBE INOX 90° - 120° - 180°



ACTIONNEURS INOX 90° - 120° - 180°

GIUGNO 2004

CARATTERISTICHE GENERALI



- Alimentazione: aria compressa filtrata, secca o lubrificata; pressione max. 8 BAR – 120 PSI (15 BAR – 225 PSI nella versione con pistoni in Acciaio INOX).
- Lubrificazione eseguita presso l'officina e garantita per 1.000.000 di manovre minimo.
- Finitura superficiale interna (Ra 0,4 – 0,6 um) per ridurre al minimo gli attriti e prolungare al massimo la vita dell'attuatore stesso.
- Guide di scorrimento in materiale a basso coefficiente d'attrito (LAT LUB), per evitare il contatto "metallo contro metallo", facilmente sostituibili per manutenzione.
- Doppia foratura inferiore, per il fissaggio della valvola, e centraggio, secondo norme ISO 5211 e DIN 3337.
- Chiave inferiore femmina del pignone, secondo norme ISO 5211 e DIN 3337, per montaggio su valvole con stelo a chiave quadra in linea e a 45°.
- Foratura dei raccordi di alimentazione secondo norme NAMUR.
- Foratura superiore, per fissaggio accessori, ed estremità superiore del pignone secondo norme NAMUR.
- Indicatore di posizione che permette il montaggio di switch-box superiori.
- Esecuzione standard per temperature -20°C +80°C (a richiesta esecuzione speciale per temperature estreme).
- Targhette adesive, con serie progressiva, punzonate in automatico.
- Collaudo funzionale e di tenuta pneumatica al 100% con apparecchiatura elettronica e certificazione singola del prodotto.

Materiali impiegati

CORPO: Acciaio INOX forgiato A182 - F316 – EN 10088/3 - 1.4401.

COPERCHI: Acciaio INOX microfuso A182 - F316 – EN 10088/3 – 1.4401.

PISTONI: Lega di alluminio pressofuso ASTM B179, anodizzati (a richiesta pistoni speciali in Acciaio INOX microfuso A182 - F316 – EN 10088/3 – 1.4401).

PIGNONE: Acciaio INOX forgiato A2.

GUIDE DI SCORRIMENTO: Resina acetalica (LAT LUB 731320T) + 20% PTFE (a richiesta PA66 ZYTEL).

VITERIA: Acciaio INOX AISI 304.

MOLLE: Precomprese a cartuccia, verniciate con polvere poliestere.

TENUTE: Gomma nitrilica NBR (a richiesta VITON o Silicone).

GRASSO: Bisolfuro di Molibdeno (a richiesta MOLYKOTE).

ALLGEMEINE EIGENSCHAFTEN



- Speisung: trockene oder geschmierte filtrierte Druckluft; Maximaldruck 8 BAR – 120 PSI (15 BAR – 225 PSI mit Rosrfreiem Stahl Kolben).
- In der Werkstatt durchgeführte Schmierung, die garantiert für mindestens 1.000.000 Arbeitsvorgänge ausreicht.
- Feinbearbeitung der internen Oberfläche (Ra 0,4 – 0,6 um), um die Reibung zu minimieren und die Lebensdauer des Antriebs selbst zu maximieren.
- Führungen aus dem Material mit niedrigem Reibungskoeffizient (LAT LUB), um den Kontakt von „Metal auf Metal“ zu vermeiden; leicht auswechselbar bei Wartung.
- Doppelte, untere Bohrung zur Fixierung des Ventils und Zentrierung entsprechend den Normen ISO 5211 e DIN 3337.
- Unterer, weiblicher Schlüssel des Ritzel, den Normen ISO 5211 e DIN 3337 entsprechen, zur Montage auf Ventile mit einer Welle mit Vierkantschlussel auf gleicher Linie und auf 45°.
- Bohrung der Speiseanschlüsse nach NAMUR-Normen.
- Obere Bohrung, zur Fixierung von Zubeör, und oberes Ritzelende nach NAMUR-Normen.
- Standortanzeiger (für oberer switch-box)
- Standardausführungen für Temperaturen von -20°C bis 80°C (Spezialausführungen auf Wunsch für extreme Temperaturen).
- Automatischer gepunzter Etikettenaufkleber mit fortlaufender Seriennummer.
- Funktions und Dichtheitsprüfung auf 100% mit elektronischer Apparatur und Einzelbeurkundung des Produkts.

Verwendete Materialien

KÖRPER: Rosrfreiem Stahl typ A182 - F316 – EN 10088/3 - 1.4401.

DECKEL: Rosrfreiem Stahl typ A182 - F316 – EN 10088/3 – 1.4401.

KOLBEN: druckgegossen aus Aluminiumlegerum nach ASTM B179, eloxiert (auf Wunsch Rosrfreiem Stahl typ A182 - F316 – EN 10088/3 – 1.4401).

RITZEL: Rosrfreiem Stahl typ A2.

FÜRUNGEN: aus Azetalharz (LAT LUB 731320T) + 20% PTFE (auf Wunsch PA66 ZYTEL).

SCHRAUBEN: aus Rosrfreiem Stahl typ AISI 304.

FEDERN: Vorspannung durch Einsatz gegeben, mit polyesterpulver lackiert.

DICHTUNGEN: aus Nitrilgummi NBR (auf Wunsch VITON oder Silicone).

FETT: MoS2 (auf Wunsch MOLYKOTE).

GENERAL FEATURES



- Supply: dry or lubricated filtered compressed air; pressure max. 8 BAR – 120 PSI (15 BAR – 225 PSI for Microcasting Stainless Steel pistons).
- The lubrication carried out by the manufacturer is guaranteed for min. 1,000,000 operations.
- Inside surface finish (Ra 0,4 – 0,6 um) to minimize friction and maximize the actuator's life.
- Piston bearing made by low friction coefficient material (LAT LUB) to avoid "metal to metal" contact, easily replaceable for maintenance.
- Double lower drilling, for fastening of the valve, and centering, according to ISO 5211 and DIN 3337 standards.
- Lower female shaft key, according to ISO 5211 and DIN 3337 standards, for assembly on valves with square key on line and 45° shaft.
- Solenoid connections according to NAMUR standards.
- Top drilling for fastening of the accessories, and upper shaft end according to NAMUR standards.
- Position indicator (fastening of upper switch-box is possible).
- Standard execution for temperatures from -20°C to +80°C (special execution for extremes temperatures on request).
- Adhesive labels on which the progressive number is automatically punched.
- Running test and 100% seal test carried out with electronic equipment and certification of each individual product.

Used Materials

BODY: Forged Stainless Steel type A182 - F316 – EN 10088/3 – 1.4401.

COVERS: Micro-casted Stainless Steel type A182 - F316 – EN 10088/3 – 1.4401.

PISTONS: Die-casted aluminium alloy ASTM B179, anodized (special pistons in Micro-casted Stainless Steel A182 - F316 – EN 10088/3 – 1.4401 on request).

SHAFT: Forged Stainless Steel type A2.

PISTON BEARINGS: acetalic resin (LAT LUB 731320T) + 20% PTFE (PA66 ZYTEL on request).

SCREWS: Stainless Steel type AISI 304.

SPRINGS: Precompressed cartridge, painted with polyester powder.

SEALS: Nitrile rubber NBR (VITON o Silicone on request).

GREASE: Molybdenum Bisulphide (MOLYKOTE on request).

CARACTERISTIQUES GENERALES



- Alimentation: air comprimé, filtré, sec ou lubrifié ; pression max. 8 BAR – 120 PSI (15 BAR – 225 PSI avec pistons en Acier Inoxydable).
- Lubrification faite à l'usine et garantie pour minimum 1.000.000 de manœuvres.
- Finissage de la surface intérieure (Ra 0,4 – 0,6 um), pour réduire ou minimum les frottements et prolonger au maximum la vie de l'actionneur.
- Glissières en matériel à bas coefficient de frottement (LAT LUB), pour éviter le contact "métal contre métal", peuvent être facilement remplacées pour l'entretien.
- Double perçage inférieur pour le fixage de la vanne, et le centrage, suivant les normes ISO 5211 e DIN 3337.
- Clef femelle inférieure du pignon, suivant les normes ISO 5211 e DIN 3337, pour montage sur vannes avec tige à clé carrée in ligne et 45°.
- Perçage des raccords d'alimentation suivant les normes NAMUR.
- Perçage supérieur, pour fixage des accessoires, et bout supérieur du pignon suivant les normes NAMUR.
- Indicateur de position permettent le montage du switch-box supérieur.
- Exécution standard pour températures de -20°C jusqu'à +80°C (exécution spéciale pour températures extrêmes, sur demande).
- Etiquette adhésive avec numéro de série progressif poinçonné automatiquement.
- Contrôle de fonctionnement et de 100% des étanchéités effectué avec un appareillage électronique et certification de chaque produit.

Matériels Utilisés

CORPS : Acier Inoxydable extrudé type A182 - F316 – EN 10088/3 - 1.4401.

COUVERCLES : Acier Inoxydable micro-moulé type A182 - F316 – EN 10088/3 – 1.4401.

PISTONS : Moulés sous pression en alliage d'aluminium ASTM B179, anodisés (pistons spéciaux en Acier Inoxydable micro-moulé type A182 - F316 – EN 10088/3 – 1.4401, sur demande).

PIGNON : Acier Inoxydable forgé type A2.

GLISSIERES : Résine Acétalique (LAT LUB 731320T) + 20% PTFE (PA66 ZYTEL, sur demande).

VIS : Acier Inoxydable type AISI 304.

RESSORTS : Précomprimée en cartouche, vernissés avec poudre polyester.

JOINTS D'ETANCHEITE : Caoutchouc nitrile NBR (VITON ou Silicone, sur demande).

GRAISSE: MoS2 (MOLYKOTE, sur demande).



(GOST)

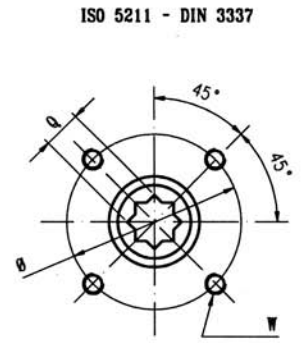
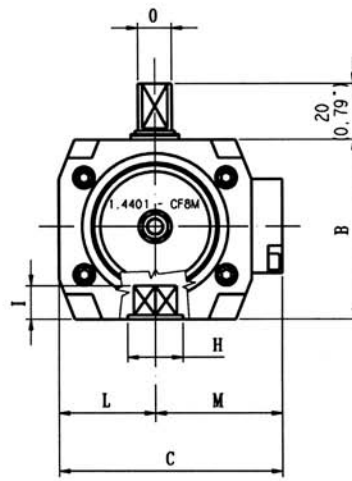
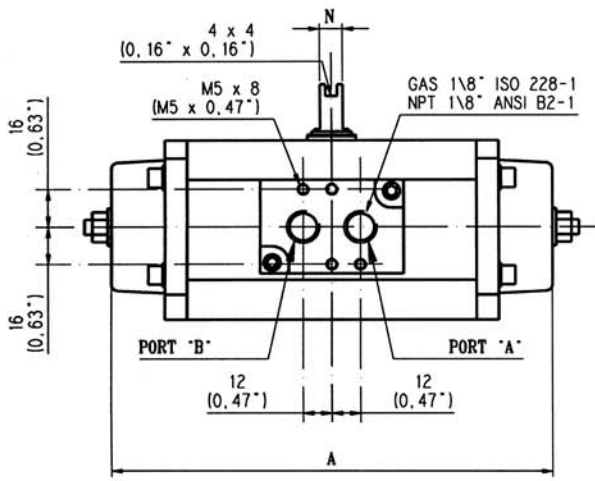

ISO 5211 - DIN 3337

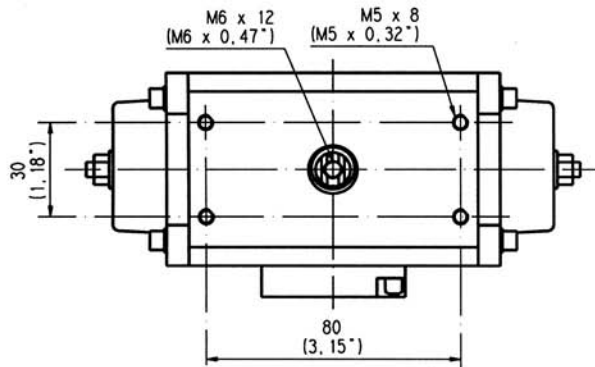

ISO 5211 - DIN 3337					
	36	42	50	70	102
Ø	36 (1.42")	42 (1.65")	50 (1.97")	70 (2.57")	102 (4.01")
W	M 5x8 (M 5x0.32")	M 5x8 (M 5x0.32")	M 6x9 (M 6x0.35")	M 8x12 (M 8x0.47")	M 10x15 (M 10x0.59")

DIMENSIONI - DIMENSIONS - MAKE - DIMENSIONS									
	ISO 5211 DIN 3337	Q x 1	A	B	C	L	M	N	O
AP 042-A	F03/05 F04	11X13 (0.43"x0.51")	140 (5.50")	57 (2.24")	71 (2.79")	30.5 (1.20")	40.5 (1.59")	8 (0.31")	12 (0.47")
	F03/05 H=25 (0.98") - F04 H=30 (1.18") TIPO - TYPE - TYP - TYPE Y (120°) A=194 (7.94") X (180°) A=230 (9.05")								
AP 063-A	F03/05 F05/07	14X16 (0.55"x0.63")	152 (5.97")	83 (3.26")	93 (3.65")	41.5 (1.63")	51.1 (2.02")	8 (0.31")	12 (0.47")
	F03/05 H=25 (0.98") - F05/07 H=30 (1.18") TIPO - TYPE - TYP - TYPE Y (120°) A=201 (7.91") X (180°) A=220 (8.66")								
AP 085-A	F05/07	17X20 (0.67"x0.79")	230 (9.04")	110 (4.32")	118 (4.64")	54 (2.12")	64 (2.52")	14 (0.55")	18 (0.71")
	F05/07 H=40 (1.57") TIPO - TYPE - TYP - TYPE Y (120°) A=282 (11.01") X (180°) A=338 (13.31")								
AP 100-A	F07/10	22X25 (0.87"x0.98")	257 (10.81")	125 (4.91")	135 (5.30")	62.5 (2.46")	72.5 (2.85")	14 (0.55")	18 (0.71")
	F07/10 H=55 (2.15") TIPO - TYPE - TYP - TYPE Y (120°) A=332 (13.07") X (180°) A=401 (15.79")								

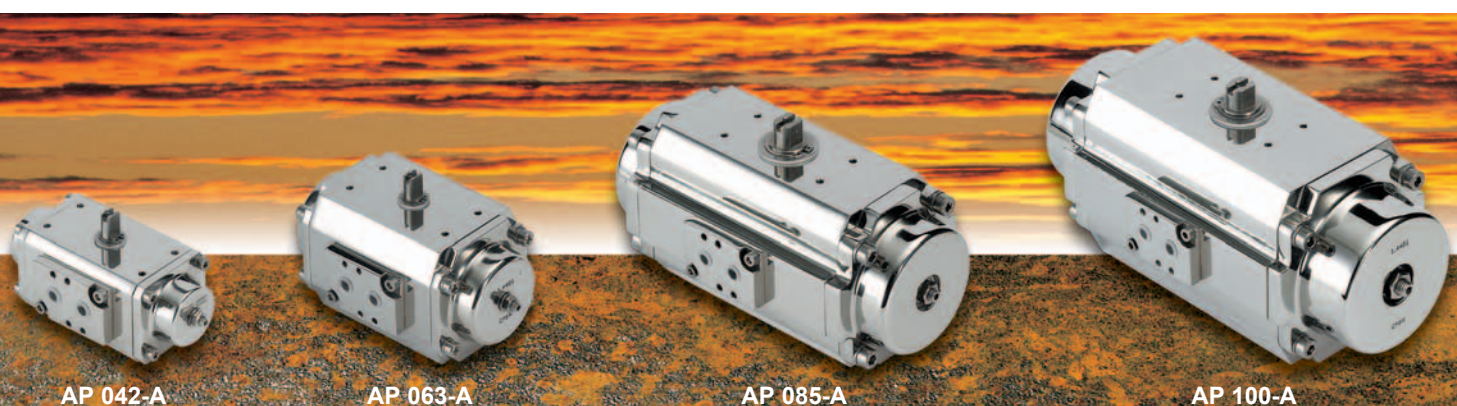

AP 042-A

AP 063-A

AP 085-A

AP 100-A

TORSIONI ATTUATORI A DOPPIO EFFETTO IN NM.

ACTUATORS DOUBLE ACTING TORQUE RATINGS IN NM

TIPO TYPE TYP TYPE	ALIMENTAZIONE ARIA IN BAR												PESO			
	PISTONI IN ALLUMINIO ALUMINIUM KOLBENS						ALLUMINIUM PISTONS PISTONS EN ALUMINIUM			ACCIAIO INOX ROSTFREI STAHL			STAINLESS STEEL ACIER INOXYDABLE			WEIGHT GEWICHT POIDS
	3	4	5	6	7	8	9	10	11	12	13	14	15			
042-A DA	6.5	8.7	10.9	13.0	15.2	17.3	19.5	21.7	23.9	26.0	28.2	30.4	32.6	KG 1.950		
063-A DA	16.5	22.0	27.5	33.0	38.5	44.0	49.5	55.0	60.5	66.0	71.5	77.0	82.5	KG 3.520		
085-A DA	53.0	71.2	89.0	106.9	124.7	142.4	160.3	178.1	195.9	213.7	231.5	249.3	267.1	KG 9.240		
100-A DA	89.02	110.9	138.6	166.4	194.1	221.8	249.5	277.3	305.0	332.8	360.5	388.2	416.0	KG 12.760		

TORSIONI ATTUATORI A SEMPLICE EFFETTO IN NM.

ACTUATORS SINGLE ACTING TORQUE RATINGS IN NM

TIPO TYPE TYP TYPE	ALIMENTAZIONE ARIA IN BAR												AIR SUPPLY IN BAR		MOLLE	SPRINGS	PESO WEIGHT GEWICHT POIDS
	0*	90*	0*	90*	0*	90*	0*	90*	0*	90*	0*	90*	0*	90*	90*	0*	
042-A SR 3/3			5.0	2.0	7.1	4.1	9.3	6.3	11.5	8.5	13.7	10.7	6.8	3.8	2,010		
042-A SR 4/4					8.1	4.1	10.2	6.2	12.4	8.4	9.0	5.0	2,030				
063-A SR 3/3	9.4	6.3	14.9	11.7	20.4	17.2	25.9	22.7	31.4	28.2	36.9	33.7	10.2	7.2	3,620		
063-A SR 4/4			12.3	8.3	17.8	13.8	23.3	19.3	28.8	24.8	34.3	30.3	13.7	9.7	3,655		
063-A SR 5/5					15.4	10.4	20.9	15.9	26.4	21.4	31.9	26.9	17.1	12.1	3,690		
063-A SR 6/6					13.0	7.0	18.5	12.5	24.0	18.0	29.5	23.5	20.5	14.5	3,720		
085-A SR 3/3	34.5	18.9	52.4	36.7	70.2	54.5	88.0	72.3	105.8	90.1	123.6	107.9	34.5	18.9	9,550		
085-A SR 4/4			46.1	25.2	63.9	43.0	81.7	60.8	99.5	78.6	117.3	96.4	46.1	25.2	9,660		
085-A SR 5/5					57.6	31.5	75.4	49.3	93.2	67.1	111.0	84.9	57.6	31.5	9,770		
085-A SR 6/6					51.5	20.0	69.1	37.8	86.9	55.6	104.7	73.4	69.1	37.8	9,880		
100-A SR 3/3	53.2	30.0	80.9	57.7	108.7	85.4	136.4	113.1	164.1	140.8	191.8	168.5	53.2	30.0	13,270		
100-A SR 4/4			70.9	40.0	98.7	67.7	126.4	95.4	154.1	123.1	181.8	150.8	70.9	40.0	13,440		
100-A SR 5/5					88.7	50.0	116.4	77.7	144.1	105.4	171.8	133.1	88.7	50.0	13,610		
100-A SR 6/6					78.7	32.2	106.4	60.0	134.1	87.7	161.8	115.4	106.4	60.0	13,780		

ATTENZIONE! TIPO "Y (120°) E "X (180°): SOLO FUNZIONAMENTO A DOPPIO EFFETTO, CON PISTONI IN ALLUMINIO

ATTENTION! PLEASE "Y (120°) E "X (180°)TYPE : ONLY DUBLE ACTING AVAILABLE,WITH ALUMINIUM PISTONS

ACHTUNG! NUR FUR TYP "Y (120°) E "X (180°): ANTRIEBS MIT DOPPELEFFEKT, MIT ALUMINIUM KOLBEENS

ATTENTION! TYPE "Y (120°) E "X (180°): SEULEMENT EN VERSION DOUBLE EFFET, AVEC PISTONS EN ALUMINIUM

